

HUMIDITY SENSORS : TYPE HU10

RELATIVE HUMIDITY TRANSMITTER UNIT

DESCRIPTION:

Non-refresh type humidity sensor made of polymer with transmitter.

FEATURES:

- Ready to use design
- Temperature compensated
- Operation up to 100%RH
- Good long term reliability
- Easy installation
- Cost effective performance
- Typical applications include humidity monitors, humidity controls, air conditioners, humidifiers, dehumidifiers, automatic ventilation

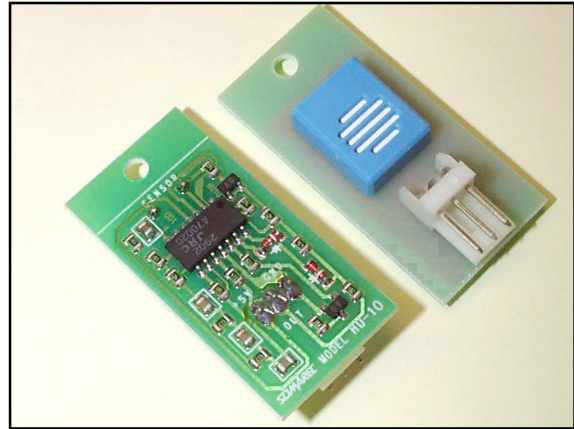

DATA:

	HU1012NA	HU1015NA
Sensing element	HS12P	HS15P
Working voltage	5 ± 0.2Vd.c.	
Operating temperature	0 - 50°C	
Operating humidity	10 - 90%RH	10 - 100%RH
Storage temperature	-30 - +50°C	-40 - +85°C
Maximum current	2mA	
Output voltage	1.0 - 3.0V d.c.	
Accuracy		
25-90% RH at 25°C	< ±5%RH	
Other range	< ±10%RH	
dependence 5-45 °C/30-80% RH	< ±5%RH	
Typical response time	1 minute	5 minutes

DIMENSIONS:

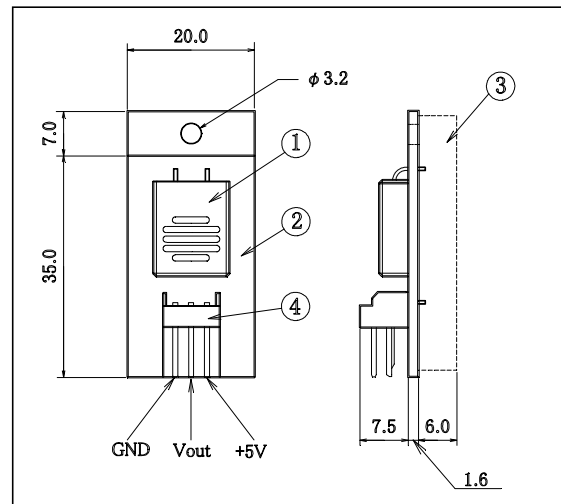

CODING:

HU1012NA: quick response type
 HU1015NA: water resistant type

- 1. Humidity sensor** HS12P or HS15P
- 2. Printed board** Glass epoxy, 1.6mm thick
- 3. Parts mounted area**
- 4. Connector** AMP 171826-3

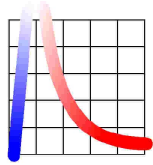

HUMIDITY SENSORS : TYPE HU10

RELATIVE HUMIDITY TRANSMITTER UNIT

MEASUREMENT CIRCUIT:

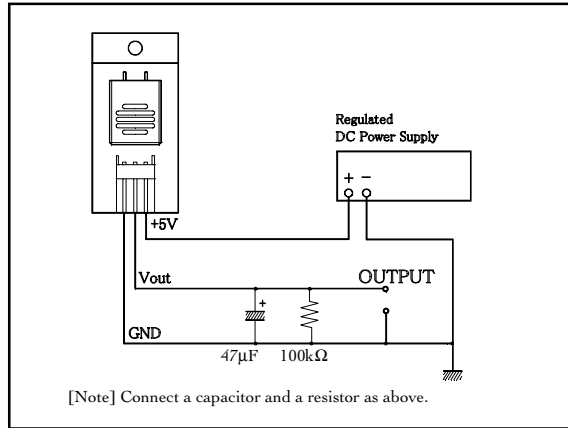

TYPICAL OUTPUT CHARACTERISTICS:

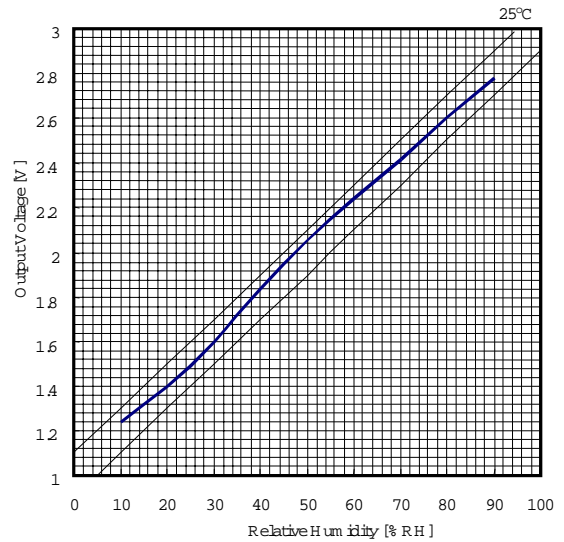

WARNING:

Use only within the specified ratings.
Do not disassemble and change any parts.